



EZ17

Tracked Zero Tail Excavator

Compact, powerful, and maneuverable

The EZ17 compact excavator is the most powerful zero tail excavator in its class. The large-volume diesel engine, LUDV (Load Sensing System) and an innovative cooling system provide the highest levels of performance and efficiency. The compact and durable design guarantees a long service life. The EZ17 offers the operator an unrestricted field of vision through the roof window.

Highlights

- Optimally protected neck and lift arm cylinder
- Powerful drive system with LUDV
- Maintenance and disassembly easier than ever before
- 100 % Zero Tail
- Canopy with roof window

Technical Data

Hydraulic

Operating pressure hydraulics	3,480.0 psi
Hydraulic pump	Variable displacement pump
flow rate	10.3 gal/mi
flow rate max.	10.3 gal/mi
tank capacity	5.5 gal US

Mechanical - Output Details

Travel speed	3.0 m/H
--------------	---------

Mechanical Details

Length	141.1 "
Width	39.0 "
Height	92.9 "
Operating weight (min.-max.)	3,800.8 - 4,592.2 lb
Digging depth (max.)	97.9 "

Engine

Cooling	Water-cooling
Engine type	Diesel engine
Cylinder	3.0
Cylinder capacity	71.8 Inch ³

Inclined position max.	30.0 °
Tank capacity	5.8 gal US
Effective power	18.5 hp
Nominal Engine speed	2,200.0 1/min
Operating power	18.0 hp
Operating Engine speed	2,200.0 1/min
Starter battery Voltage	12.0 V
Battery capacity (nom. value)	44.0 Ah
Engine Manufacturer	Yanmar
Engine Designation	3TNV76-XNSV

Environment Data

Sound level LpA	79.0 dB(A)
Sound power LWA, guaranteed	93.0 dB(A)

Operating Fluids

Fuel specification	Diesel EN 590
--------------------	---------------

Chassis

operating pressure	3,480.0 psi
--------------------	-------------

Shipping and Storage

Shipping weight	3,518.6 lb
-----------------	------------

Dimensions

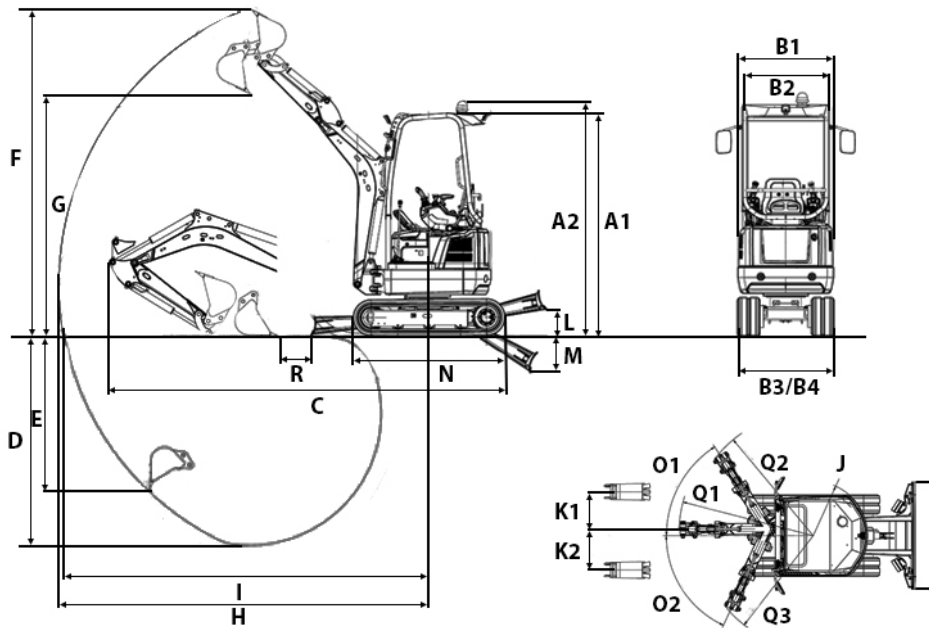

A2	Height with cab	92.99 in
A6	Total height with rotating beacon	99.9 in
B1	Width of upper carriage	38.6 in
B2	Width of cab	34.8 in
B3	Width travel gear	51.2 in
B4	Width travel gear retracted	39.0 in
B5	Width of dozer blade	51.2 in
C1	Transport length	111.42 in
C2	Transport length short shovel arm	141.1 in
C3	Transport length long shovel arm	139.8 in
D2	Digging depth max., short shovel arm	91.57 in
D3	Digging depth max., long shovel arm	97.87 in
E2	Piercing depth max., short shovel arm	67.44 in
E3	Piercing depth max., long shovel arm	73.35 in
F2	Piercing height max., short shovel arm	136.3 in
F3	Piercing height max., long shovel arm	140.79 in
G2	Dumping height max., short shovel arm	95.91 in
G3	Dumping height max., long shovel arm	100.3 in
H2	Digging radius max., short shovel arm	153.5 in
H3	Digging radius max., long shovel arm	159.4 in
I2	Max. reach at ground level (short shovel arm)	151.5 in
I3	Max. reach at ground level (long shovel arm)	157.56 in
J1	Tail swing radius	25.98 in
K1	Boom offset max. (to center of bucket right side)	20.98 in
K2	Boom offset max. (to center of bucket left side)	16.46 in
L1	Stacking height max. (dozer blade above surface)	10.6 in
M1	Digging depth max. (dozer blade below surface)	15.2 in
N1	Length travel drive	63.27 in
O1	Max. swivel angle (arm system to the left)	65 °
O2	Max. swivel angle (arm system to the right)	57 °
P1	Track width	9.06 in
Q1	Boom swing radius center	64.06 in
Q2	Boom swing radius right	59.8 in
Q3	Boom swing radius left	54.02 in
R1	Distance bucket dozer blade, short shovel arm	13 in
R2	Distance bucket dozer blade, long shovel arm	10.2 in

The illustrations, equipment and data shown may deviate from the current delivery program of your country. Optional equipment subject to additional charge may be shown. Subject to changes.